

# DUAL HD/SD Distribution Amplifier

Model: PA-402-3G

- Dual 1x4 or Single 1x8
- True 75 ohm coaxial in and out
- Auto equalizing
- Multi-rate reclocking upto 3GB
- Supports all hd/sd formats
- Removes high frequency jitter
- Compatible with PA3200HD, PA1600HD and PA10032
- Lock and eq. warning indicators
- Signal meter and fault outputs

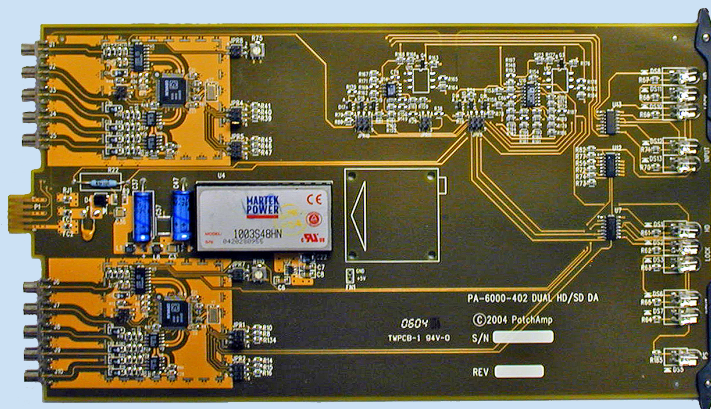

## Technical Specifications:

### Input

Number of Inputs	2
Input Connection	75 Ohm BNC
Input Impedance	75 Ohm
Input Return Loss	>10dB up to 3.0GHz
Signal Level	800mV +/-10%

### Output

Channels	Single or Dual
Outputs per Channel	Single-8 or Dual-4
Output Connection	75 Ohm BNC
Output Impedance	75 Ohm
Output Return Loss	>10dB up to 3.0GHz

### Performance

Standards	SMPTE 424M, 292M, 259M, 344M
Data Rates	143, 177, 270, 360, 540, 1483.5, 1485, 2970 Mb/s
Equalization Mode	Automatic Multi-Rate
Reclocking	Multi-Rate
Signal Level	800mV Nominal
DC Offset	0V +/-0.5V
Rise & Fall Time	135ps nominal
Overshoot	< 10% of amplitude
Wideband Jitter	< 0.2 UI

### BLOCK DIAGRAM

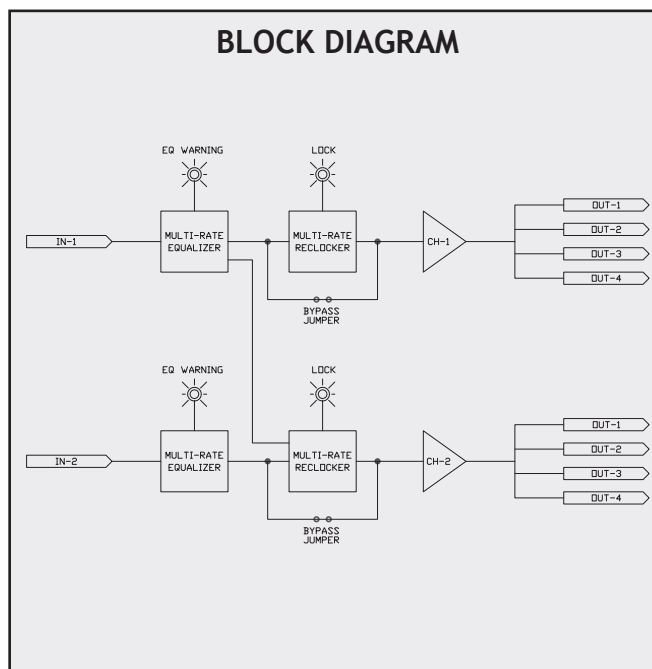

**PATCHAMP**  
PATCHING & DISTRIBUTION TECHNOLOGY

20 East Kennedy Street, Hackensack, NJ 07601  
201-457-1504 Fax: 201-457-1507  
www.patchamp.com